

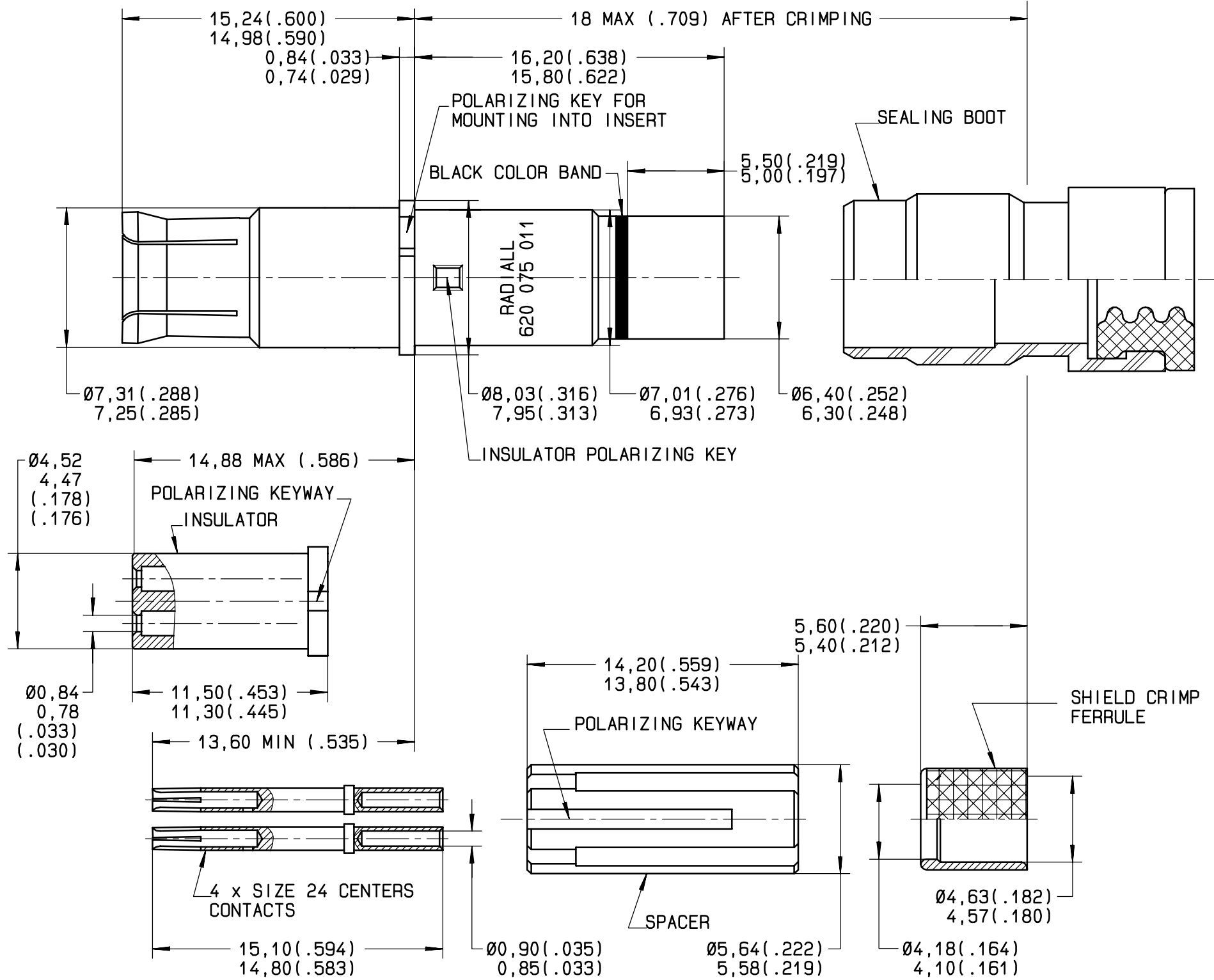

Series
NSX

ENVIRONMENTAL SIZE 8 QUADRAX SOCKET CONTACT
FOR QUAD ETHERNET CABLES
(SEE NOTES)

Issue: 20 FEBRUARY 2003
Page 1 / 1



ENGAGING FACE

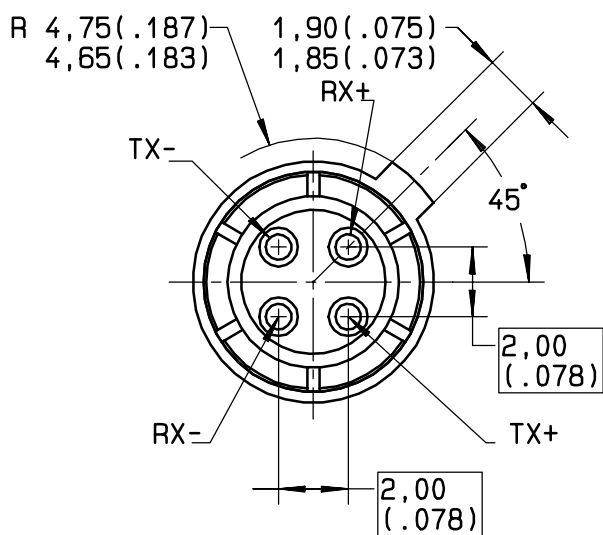

*MATERIAL :

- OUTER AND CENTER CONTACTS: BERYLIUM COPPER PER ASTM-B-196
- FERRULE: BRASS PER QQ-B-626
- INSULATOR AND SPACER: FPTE PER ASTM-D-1710 OR EQUIVALENT
- SEALING BOOT: THERMOPLASTIC PER MIL-P-46184 AND FLUOROSILICONE PER MIL-R-25988 OR PER ZZ-R-765

*FINISH:

- ALL METAL PARTS:
PLATING .00005 INCH OF GOLD PER MIL-G-45204 TYPE I OR II
GRADE C OR D CLASS 1 OVER NICKEL PER QQ-N-290

*EXTRACTION TOOL :

- M81969/28.03 (RADIALL: 282 549 001) OR M81969/14-06

WIRING INSTRUCTIONS: SEE RP55178

CABLES	
MANUFACTURER	P/N
DRAKA FILECA	F 4703-2
AXON	TBD
HABIA	TBD

This information is given as an indication. In the continual goal to improve our products, we reserve the right to make any modifications judged necessary.

4112-9610

CREATION
PEN: M010400049G
NOM: MACARI
DATE: 27 MARCH 02	20 FEB 03	Add black color band of contact body	Couthon	B VDM
APPR.: .	04/09/02	Added M81969/14-06	B VDM	.
	Issue	Revisions	Name	Approved